

CAD FILE:

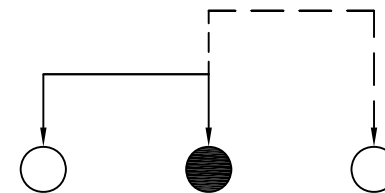

SCHEMATIC (NON-SHORTING)

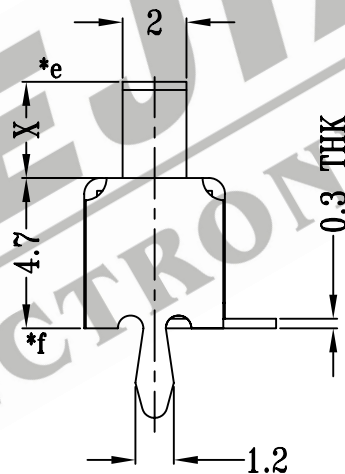
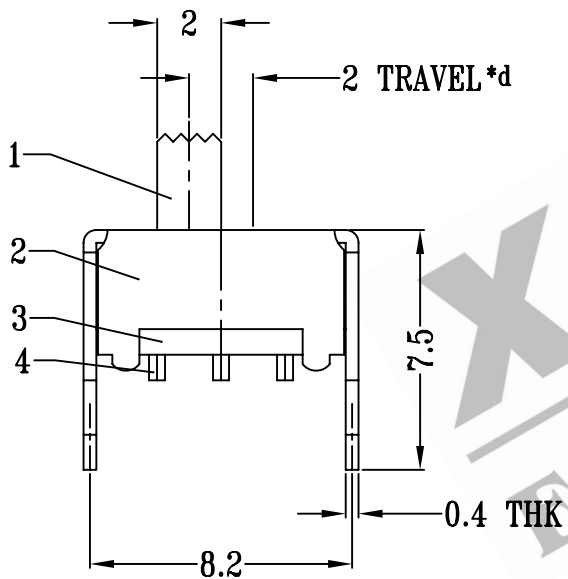
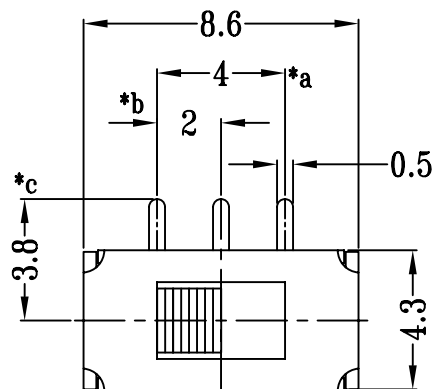
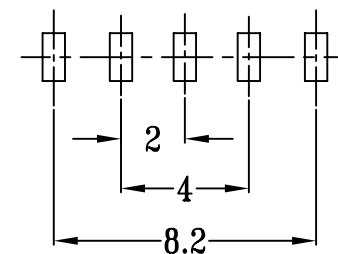

P.C.B LAYOUT

注:带"*"表示关键尺寸(6个)

				TOLERANCE UNLESS SPECIFIED		SHENZHEN XIEJIA ELECTRONICS CO.,LTD.					
				WITHIN: 1.5±0.1mm OVER : 1.5±0.2mm		ISSUE	DATE	DESCRIPTIONS OF REVISION		APPD.	
8											
7											
6	SPRING PLATE	STAINLESS STEEL	1	NATURAL	TITLE : VERTICAL SLIDE SWITCH		UNIT : mm		DRWG NO.: XJ-DR-SS12D25-00		
5	CONTACT CLIP	PBS STRIP	1	Ag PLATED							
4	TERMINAL	BRASS STRIP	3	Ag PLATED OVER Ni PLATED	MODEL: SS-12D25		SCALE: 4:1		DWN.	ZHOUYU	2002-7-5
3	BASE	PHENOLIC RESIN	1	NATURAL					CHK'D	FANGYING	2002-7-5
2	FRAME	STEEL STRIP	1	Ni PLATED	ALL MATERIALS MUST BE COMPLIANT TO ROHS		APPD.		KANGXINAN	2002-7-5	
1	KNOB	POM	1	BLACK							
NO.	PARTS	MATERIALS	Q'TY	FINISH							